

# ***Needle Valves (VL Series)***

*Catalog 4110-VL  
March 2000*



# VL Series Needle Valves

## Introduction

The Parker VL Series Needle Valves are excellent for applications involving passive media at moderate pressures. For many, they are the right combination of performance and value. These screwed bonnet designs are manufactured from brass forgings and are standard with PTFE packing below the stem threads. Two PTFE coated stem tip options provide repetitive tight shut-off and/or coarse regulation in both liquid and gaseous service.

## Features

- Packing below thread design, protects media and thread lubricant
- Externally adjusted PTFE packing
- Blunt stem (**R**) for on-off control
- Regulating (**N**) stem for coarse regulation
- Forged brass body construction
- Inline and angle patterns
- Optional panel mounting design
- Optional colored handles

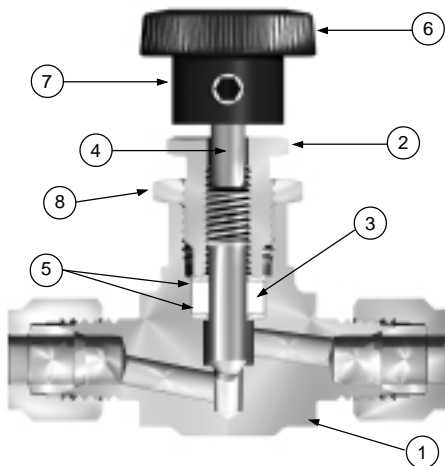

Model Shown: 4Z-VL4LN-B

## Specifications

Pressure Rating at all temperatures:  
600 psig CWP (41 bar)

Temperature Rating:  
-40 °F to 300 °F (-40 °C to 149 °C)

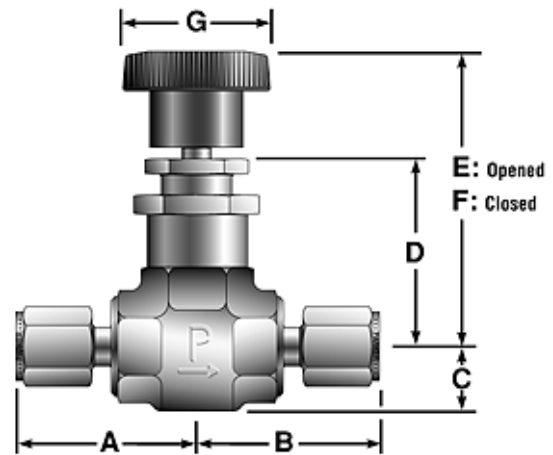

Model Shown: 4Z-VL4LR-B

## Materials of Construction

Item #	Description	Material
1	Body	ASTM B 283 Alloy C37700
2	Bonnet	ASTM B 16 Alloy C36000
3	Packing	PTFE
4	Stem	ASTM B 98 Alloy C66100
5	Packing Washer	Stainless Steel
6	Handle	Nylon 6/6 with SS insert
7	Handle Screw	Stainless Steel
8	Lock Nut	ASTM B 16 Alloy C36000
9	Panel Nut*	ASTM B 16 Alloy C36000

\* Not shown  
Lubrication: Molybdenum disulfide with metallic fillers

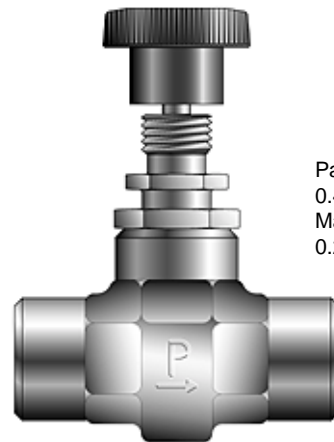

Panel Hole Diameter:  
0.45 (11.4mm)  
Max Panel Thickness:  
0.25 (6.4mm)

Model Shown: 4F-VL4LN-BP

## Dimensions / Flow Data

Basic		End Connections		Stem	Dimensions																				
Part Number		Inlet	Outlet		Type	Orifice**		Inline		Angle		A†		B†		C		D		E††		F††		G	
Inline	Angle	(Port 1)	(Port 2)			Inch	mm	C <sub>v</sub>	x <sub>r</sub> *	C <sub>v</sub>	x <sub>r</sub> *	Inch	mm	Inch	mm	Inch	mm	Inch	mm	Inch	mm	Inch	mm	Inch	mm
2A-VL4LR 2A-VL4LN	2A-VL4AR 2A-VL4AN	1/8" Compression A-LOK®		Blunt Regulating	0.094	2.4	0.12 0.10	0.58 0.55	0.22 0.18	0.52 0.48	1.14	29.0	1.14	29.0	0.41	10.4	1.18	30.0	2.03	51.6	1.86	47.2	0.94	23.9	
2M-VL4LR 2M-VL4LN	2M-VL4AR 2M-VL4AN	1/8" Male NPT		Blunt Regulating	0.156	4.0	0.26 0.25	0.61 0.67	0.47 0.46	0.66 0.63	0.88	22.4	0.88	22.4	0.41	10.4	1.18	30.0	2.03	51.6	1.86	47.2	0.94	23.9	
2Z-VL4LR 2Z-VL4LN	2Z-VL4AR 2Z-VL4AN	1/8" Compression CPI™		Blunt Regulating	0.094	2.4	0.12 0.10	0.58 0.55	0.22 0.18	0.52 0.48	1.14	29.0	1.14	29.0	0.41	10.4	1.18	30.0	2.03	51.6	1.86	47.2	0.94	23.9	
4A-VL4LR 4A-VL4LN	4A-VL4AR 4A-VL4AN	1/4" Compression A-LOK®		Blunt Regulating	0.156	4.0	0.42 0.32	0.78 0.68	0.47 0.46	0.66 0.63	1.17	29.7	1.17	29.7	0.41	10.4	1.18	30.0	2.03	51.6	1.86	47.2	0.94	23.9	
4M-VL4LR 4M-VL4LN	4M-VL4AR 4M-VL4AN	1/4" Male NPT		Blunt Regulating	0.156	4.0	0.42 0.32	0.78 0.68	0.47 0.46	0.66 0.63	0.92	23.4	0.92	23.4	0.41	10.4	1.18	30.0	2.03	51.6	1.86	47.2	0.94	23.9	
4Z-VL4LR 4Z-VL4LN	4Z-VL4AR 4Z-VL4AN	1/4" Compression CPI™		Blunt Regulating	0.156	4.0	0.42 0.32	0.78 0.68	0.47 0.46	0.66 0.63	1.17	29.7	1.17	29.7	0.41	10.4	1.18	30.0	2.03	51.6	1.86	47.2	0.94	23.9	
6A-VL4LR 6A-VL4LN	6A-VL4AR 6A-VL4AN	3/8" Compression A-LOK®		Blunt Regulating	0.156	4.0	0.42 0.32	0.78 0.68	0.47 0.46	0.66 0.63	1.21	30.7	1.21	30.7	0.41	10.4	1.18	30.0	2.03	51.6	1.86	47.2	0.94	23.9	
6Z-VL4LR 6Z-VL4LN	6Z-VL4AR 6Z-VL4AN	3/8" Compression CPI™		Blunt Regulating	0.156	4.0	0.42 0.32	0.78 0.68	0.47 0.46	0.66 0.63	1.21	30.7	1.21	30.7	0.41	10.4	1.18	30.0	2.03	51.6	1.86	47.2	0.94	23.9	
M6A-VL4LR M6A-VL4LN	M6A-VL4AR M6A-VL4AN	6mm Compression A-LOK®		Blunt Regulating	0.156	4.0	0.42 0.32	0.78 0.68	0.47 0.46	0.66 0.63	1.17	29.7	1.17	29.7	0.41	10.4	1.18	30.0	2.03	51.6	1.86	47.2	0.94	23.9	
M6Z-VL4LR M6Z-VL4LN	M6Z-VL4AR M6Z-VL4AN	6mm Compression CPI™		Blunt Regulating	0.156	4.0	0.42 0.32	0.78 0.68	0.47 0.46	0.66 0.63	1.17	29.7	1.17	29.7	0.41	10.4	1.18	30.0	2.03	51.6	1.86	47.2	0.94	23.9	
4F-VL6LR 4F-VL6LN	4F-VL6AR 4F-VL6AN	1/4" Female NPT		Blunt Regulating	0.156	4.0	0.42 0.32	0.78 0.68	0.47 0.46	0.66 0.63	1.03	26.2	1.03	26.2	0.41	10.4	1.18	30.0	2.03	51.6	1.86	47.2	0.94	23.9	

\* Tested in accordance with ISA S75.02. Gas flow will be choked when  $P_1 - P_2 / P_1 = x_r$

\*\* Orifice on 2Z(A)-VL4L is .082 (2.1 mm); orifice on 2M-VL4L is .125 (3.2 mm)

† For CPI™ and A-LOK®, dimensions are measured with nuts in the finger-tight position

†† For panel mountable valves, E=2.40 (61.0 mm); F= 2.23 (56.6 mm)

## How To Order

The correct part number is easily derived from the following number sequence. The five product characteristics required are coded as shown below. \*Note: If the inlet and outlet ports are the same, eliminate the outlet port designator.

Example:  $\frac{4Z}{\textcircled{1}}$  -  $\frac{VL4L}{\textcircled{3}}$  -  $\frac{N}{\textcircled{4}}$  -  $\frac{B}{\textcircled{5}}$   
 Inlet Port      Outlet Port      Valve Series      Stem (N or R)      Body Material

Describes a VL4 Series inline pattern needle valve equipped with 1/4" CPI™ compression inlet and outlet ports, N-stem option, and brass construction.

## How to Order Options

**Colored Nylon Handles** - Add the designator corresponding to the correct handle color as a suffix to the part number. Black is standard, **W** - white, **B** - blue, **G** - green, **R** - red, **Y** - yellow. Example: 4A-VL4LR-BP-R

**Panel Mounting** - Add the suffix **P** to the end of the part number to receive valves suitable for panel mounting.

Example: 4M-VL4AB-BP

**Oxygen Cleaning** - Add the suffix **-C3** to the end of the part number to receive valves cleaned and assembled for oxygen service in accordance with Parker Specification ES8003. Example: 6Z-VL4AN-B-C3

### WARNING

FAILURE, IMPROPER SELECTION OR IMPROPER USE OF THE PRODUCTS AND/OR SYSTEMS DESCRIBED HEREIN OR RELATED ITEMS CAN CAUSE DEATH, PERSONAL INJURY AND PROPERTY DAMAGE.

This document and other information from Parker Hannifin Corporation, its subsidiaries and authorized distributors provide product and/or system options for further investigation by users having technical expertise. It is important that you analyze all aspects of your application and review the information concerning the product or system in the current product catalog. Due to the variety of operating conditions and applications for these products or systems, the user, through its own analysis and testing, is solely responsible for making the final selection of the products and systems and assuring that all performance, safety and warning requirements of the application are met.

The products described herein, including without limitation, product features, specifications, designs, availability and pricing, are subject to change by Parker Hannifin Corporation and its subsidiaries at any time without notice.

### Offer of Sale

The items described in this document are hereby offered for sale by Parker Hannifin Corporation, its subsidiaries or its authorized distributors. This offer and its acceptance are governed by the provisions stated in the "Offer of Sale" located in Catalog 4110-U Needle Valves (U Series).

© Copyright 2000, Parker Hannifin Corporation. All Rights Reserved.



Catalog 4110-VL, 20M, 03/00

**Parker Hannifin Corporation**  
Instrumentation Valve Division  
2651 Alabama Highway 21 North  
Jacksonville, AL 36265-9681  
Phone: (256) 435-2130  
Fax: (256) 435-7718  
[www.parker.com/IVD](http://www.parker.com/IVD)

